

# Lipstick moulding techniques— comparison and statistical analysis

By A.C. DWECK and C.A.M. BURNHAM  
Smith & Nephew Cosmetics, Surbiton, Surrey, England\*

Lipsticks form an intrinsic part of most cosmetic companies' product ranges, and since lipstick production consumes a high tonnage of raw materials each year, it provides an interesting subject for discussion.<sup>1-7</sup> This paper intends to examine two methods of manufacture and three moulding techniques for lipsticks. The mouldings from each test were critically examined, using physical test methods for pay-off, hardness, and stick strength; the information was then collated and statistically analysed.

## Methods of manufacture

Two methods were examined, the stock concentrate method and the direct method. (See figure 1.)

### Stock concentrate method

This method involves the production of a stock concentrate of colour in a castor oil base. The pigment to binder (in this case castor oil) grinding ratio is calculated to achieve maximum working on the pigment and hence maximum colour development. The colour and castor oil are premixed using a shear headed mixer to give an even slurry, which is then fed into one of several alternative mills; roller mill, sand mill, corundum mill, or ball or pebble mill. There are many views on which method is best.<sup>4,7-11</sup>

The waxes are then weighed and dispensed into a steam pan and allowed to melt. Once the waxes have melted the colour concentrates together with any remaining castor oil are dispensed into the steam pan and mixed for 5-10 min using a shear head mixer, the temperature being maintained at around 85°C. Once the

waxes and colour concentrate have been well dispersed, the pearl material (if any) is added, and a stick is moulded. The stick is then checked by quality control and corrections, if required, are made. The perfume is added at 75°C and mixed in for a few minutes, and then the bulk poured off into trays.

### Direct method

In the direct method, the waxes are weighed into the mixer and the vessel heated to 85°C. Once the waxes have melted the castor oil is introduced, the vessel lid lowered, and the temperature allowed to fall to 75°C. Mixing is started using anchor blades only. The pigments and lakes are weighed into a suitable container, the mixer put under a vacuum of between half and one atmosphere, and the pigments slowly drawn in with the vacuum pump running via the bottom pipe of the mixer. The colloid mill or dispersion head should be running during the addition of the colourants. Once the pigments have been introduced, the colloid mill and anchor blades continue to run for 30 min whilst maintaining the mixer at a half atmosphere of vacuum. This greatly reduces entrapment of air in the product. Any pearl material in the formula would be drawn in under the vacuum at this stage. The completion of manufacture would then follow the stock concentrate method.

\*Direct correspondence to Mr. A. C. Dweck at his current place of employment: Chempac Ltd., Kingsford Industrial Building, Phase 2, 21st & 22nd Floors, 26-32 Kwai Hei Street, Kwai Chung, New Territories, Hong Kong.

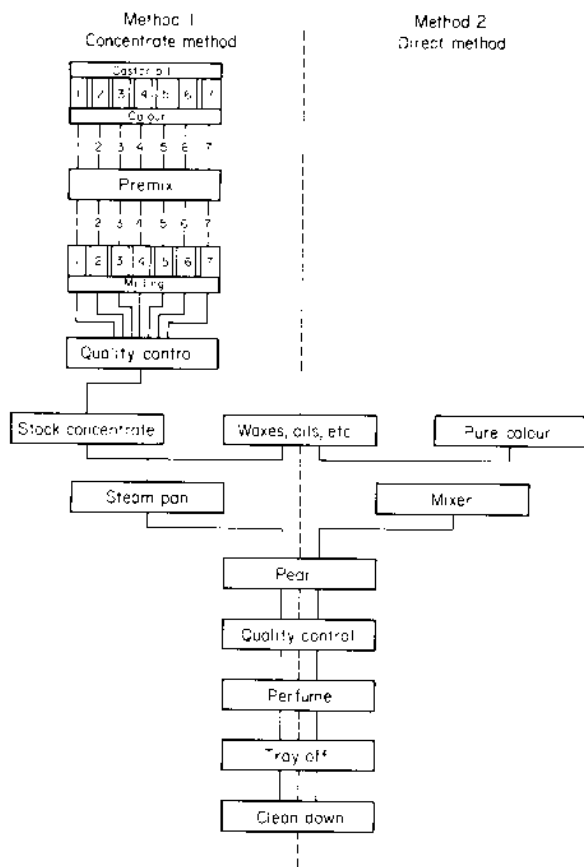

Figure 1. Methods of lipstick manufacture.

### Advantages and disadvantages

With the stock concentrate method, we are able to compensate for strength differences of incoming pigments; it also offers fast clean down time of steam pan and optimum colour development and associated cost saving as a result of using the best pigment to binder grinding ratio. The operator needs less skill to operate this method than when using the closed mixer.

With the direct method, the number of stages in manufacture are reduced. Quality control involvement is also reduced, as are labour costs. Storage area requirements are reduced, as are the number of formulae handled by manufacturing. There is a time saving on formula manufacture. Bulk aeration is reduced. Finally, there is a reduction in the amount of equipment used, and also in cleaning downtime.

The stock concentrate method requires the making of up to twenty concentrates. This is time consuming; it is also expensive, requiring colloid mills or stones for each colour. In addition, concentrates require stirring at least once a day to maintain dispersion; there is a concentration gradient throughout the drum if the concentrates are not stirred, and the bulk can become aerated. Extra storage area is also required for concentrates.

On the other hand, the direct method presents

the need to handle neat pigment/dyestuff, which is unpleasant. There is also a need to know strength differences of incoming colour and alter each formula according to batch or lot used. Clean down time of mixer is lengthy compared to steam pan, while colour matching is difficult because additions are small. As a result of this, tinted wax bases may be needed. Mixers are costly compared to the added cost of steam pan and colloid mill. This method offers no facility to optimise colour development, i.e. pigment to binder grinding ratio. It is harder to pinpoint the source of trouble in colour matching, i.e., whether the colour strength of the pigment is low or pigment weighing is inaccurate.

Breakdowns of the times taken for lipstick manufacture by the concentrate method and the direct method show that the direct method saves 13 min, assuming no colour matching. In practice, the direct method is considerably more accurate for colour and therefore saves even more time.

### Methods of moulding

Labour cost is inversely proportional to production costs. Split moulding requires experienced moulders to reach target production, which in turn requires higher hourly rates for the skill required. Even so, the rate of production cannot match mechanised methods.<sup>12</sup>

#### Split moulding

The following description refers to a single mould operation. In fact, each station would operate a three to four mould rotation.

Split moulding begins with the delivery of the tray from the manufacturing area. It is cut out, placed in a steam pan at 60°C, and stirred continuously.

In the next procedure, dispensing, the mass is held at 85 ± 5°C, and kept stirring with a slow paddle stirrer. The ideal nozzle size delivers mass at a reasonable pace, allowing it to flow first down one side of the mould cavity and then up the other without premature setting of the mass, and without the production of turbulence. The ideal rate is about one row of cavities. The rate of dispenser stirring obviously depends on the shape of the paddle, but the top of the molten mass should show a gentle ripple. It is too fast if the surface is broken by vortexes, and too slow if the surface barely appears to be circulating. A pearl lipstick should be stirred slightly faster than a plain shade to prevent pearl fall out.

Once the mould has been stripped of its bullets, the cavities should be rubbed down with a soft cloth to remove traces of lipstick which may have adhered. The mould is then reassembled and clamped. A swab is dipped into the chosen release agent and excess oil squeezed off. It is recoiled after each length of cavities (normally 20 per line) and the next line oiled. If the operation has been performed successfully, only a trace of oil should be on the mould surface and there should be no droplets of oil at the cavity tip.

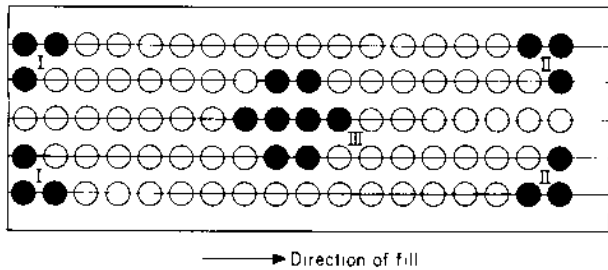

Figure 2. Lipstick mould, showing direction of fill and areas of greatest interest.

The freshly oiled mould is placed onto the hot plate for about 5 min until it is just above lukewarm, approx. 45°C. The dispenser is run off slowly at first to clear the first few rows of cavities, and the flow rate gradually increased to maximum. Once the mould has been filled it is allowed to sit on the bench at ambient temperature for 3-5 min until the top sets and dimples start to appear over the cavities. The mould will feel cooler, just warm to the touch (about 40°C) and when the dimples are fairly pronounced, but full coring not evident, the surface mass is removed with a scraper and the mould placed on a cold surface. The mould is removed when it feels cold and the clamps are removed. The sticks are examined carefully and packed off into tins.

A plain, pearl, and glosser shade were moulded via the direct and concentrate methods under the conditions mentioned in this report. The direction of pouring was carefully noted, and sticks laid out in mould order. The areas of greatest interest are theoretically anticipated as areas I, II, and III in figure 2.

#### Rotomould method

The dispenser is kept at a temperature of between 75°C and 85°C, depending on the set point of the bulk. The dispenser has twin nozzles that release bulk into a pair of cavities that pass beneath in a large moving ring containing such pairs of cavities. The rotating ring passes through three areas: the prewarming chamber (prior to filling); the cooling chamber (immediately after filling); the refrigerated chamber (prior to ejection). Immediately after the filling head are two top heaters to ensure that the bulk sets from the bottom of the cavity upwards, by keeping the top molten. This prevents contraction deformation in the stick. Eventually the cavities align under a plate containing two sockets, into which two empty cases are placed inverted. Compressed air is blasted through the base of the cavity, shooting the lipstick bullet into the case. The lipsticks are passed to a moving belt on which they are flamed and the mechanism wound down, caps assembled, and so forth. See figure 3.

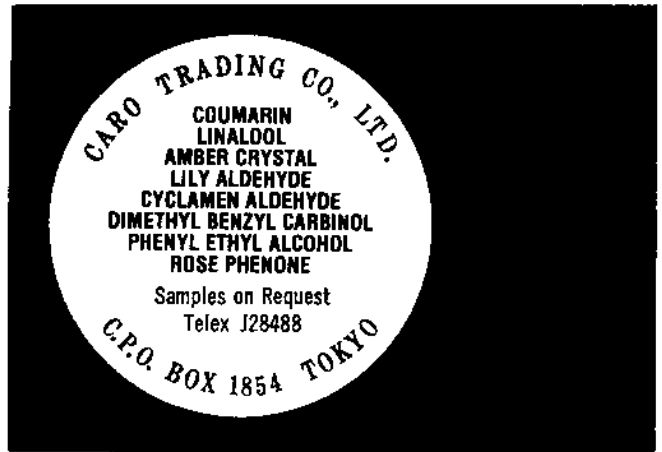

*Additional copies of the*

## **MAKEUP**

**Documentary/Formulary**

*and copies of the*

## **PRESERVATIVES DOCUMENTARY**

*are available @ \$8.00*

*Send this order form to  
Allured Publishing Corp.  
P.O. Box 318  
Wheaton, IL 60187 U.S.A.*

-----  
*Please send \_\_\_\_\_ copies of the  
March 1981 Preservatives Docu-  
mentary.*

*Please send \_\_\_\_\_ copies of the  
April 1981 MAKEUP Documen-  
tary/Formulary.*

*Name* \_\_\_\_\_

*Company* \_\_\_\_\_

*Address* \_\_\_\_\_

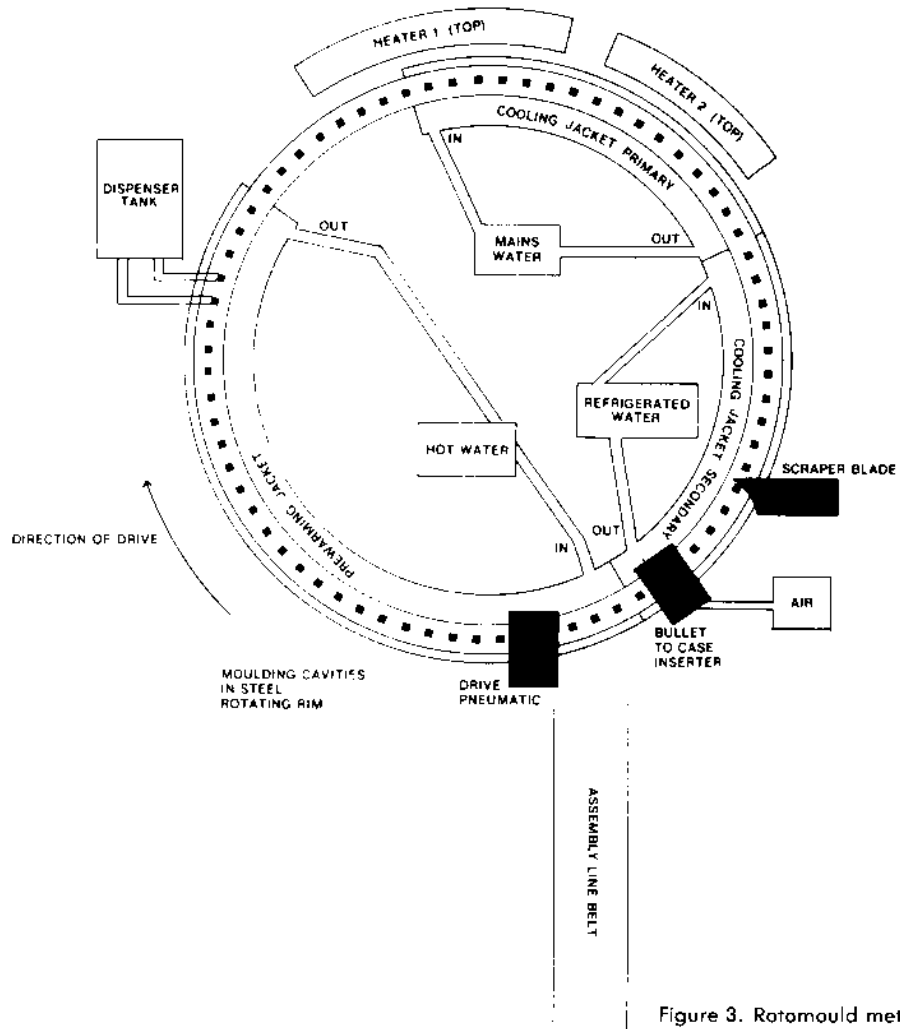
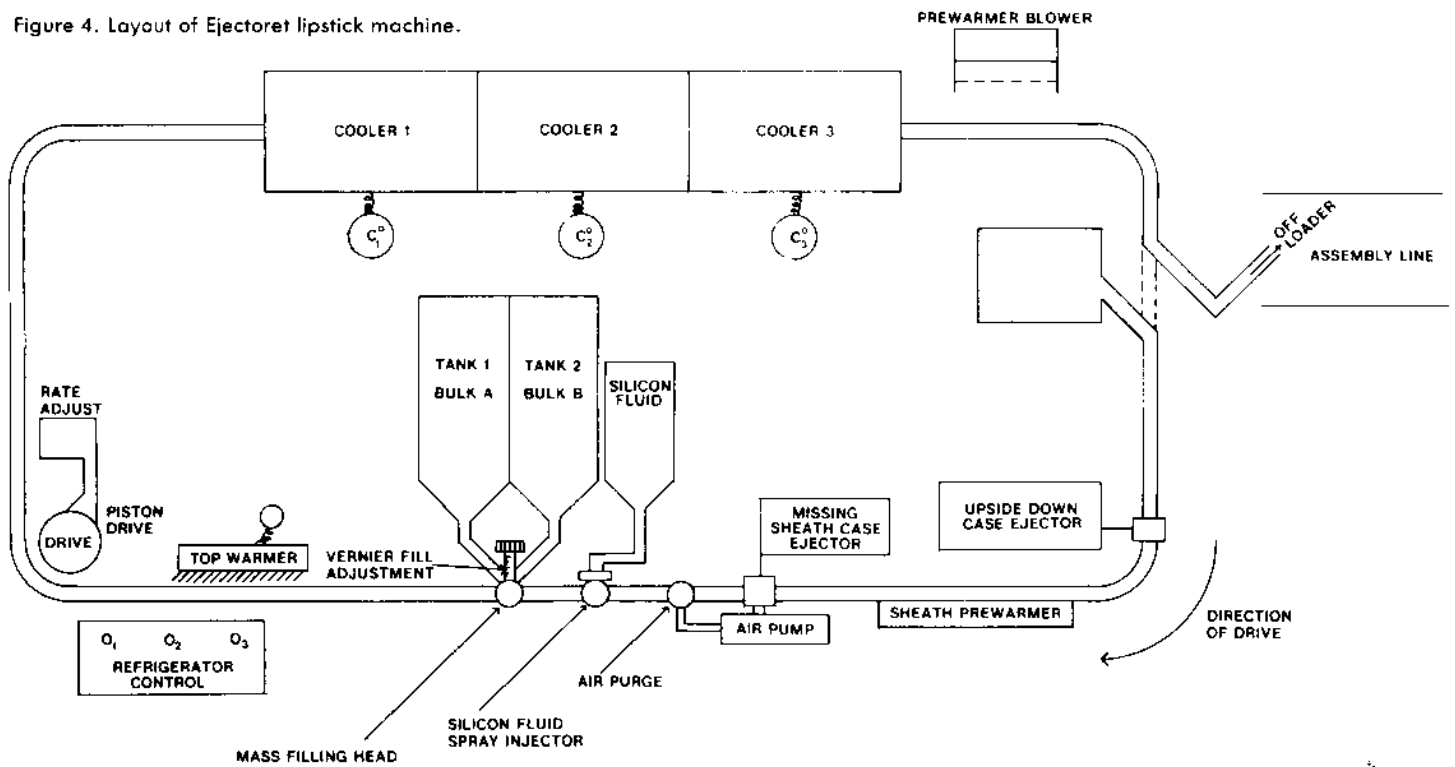

Figure 3. Rotomould method of moulding.

Figure 4. Layout of Ejectoret lipstick machine.



**Table I.** Comparison of faults with type of moulding

Moulding method	Aeration	Laddering	Cracking	Deformation	Cratering	Streaking	Sweating	Mushy failure	Low gloss
Split moulding	Often	Sometimes	Rarely	Sometimes	Sometimes	In high $TiO_2$ concentrate often	Depends on formula	Often	Always, requires flaming which can give further faults
Rotamoulding <sup>©</sup>	Often	Sometimes	Never	Sometimes	Sometimes	Rarely	Depends on formula	Sometimes	Always requires flaming, which gives further faults.
Ejectoret <sup>©</sup> moulding	Sometimes	Sometimes	Never	Sometimes	Never	Never	Depends on formula	Never	Initially but after 1 h never

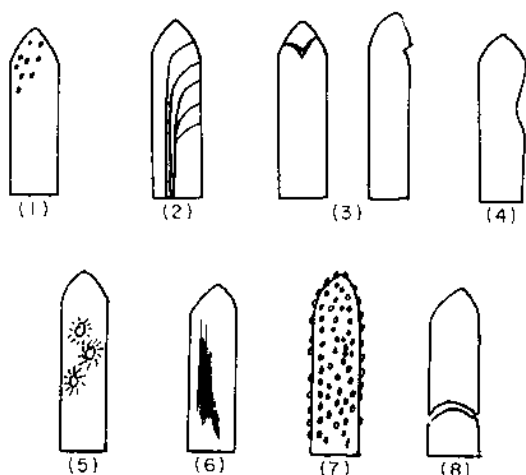

Figure 5. Problems associated with lipstick bullets: (1) aeration, pinholing, (2) laddering, (3) cracking or chipping, (4) deformation, (5) cratering, (6) streaking, (7) sweating, and (8) mushy failure. An additional problem is gloss, which is not illustrated here.

#### Ejectoret machine

The following parameters should be satisfactorily adjusted prior to operating the machine.<sup>13,14</sup> (The layout of the machine is shown in figure 4.)

**Mass holding tank.** This should be set at around 85°C, which is approximately 15°C above the setting point of the lipstick mass. The cooling and heating coils around the tank ensure that the set temperature can be maintained  $\pm 0.5^\circ\text{C}$ .

**Silicone oil release agent spray.** The machine should be allowed to run through the silicon spray head and mass filling head with six lipsticks, then allowed to cool for a few minutes until set. The sheaths should then be ejected and the bullets examined. A normal stick usually

exhibits a sheen on one side extending over about 60% of the total visible surface of the bullet. Increase or decrease of the silicon oil required may be facilitated by means of the silicon spray timer located on the control panel. The oil will migrate, once the sheaths have been removed, to cover the remainder of the stick, which may originally have been dull.

**Adjustment of mass fill.** The adjustment of the fill weight can be carried out at the same time as the adjustment of silicon fluid spray. The machine has a calibrated vernier adjustment on the nozzle that presets the fill accurately.

**Adjustment of the top warmer.** The function of this stage is to prevent the top from setting before the middle of the stick has set, otherwise contraction dents can form at the centre of the stick instead of via the coring process at the top. A suitable setting would be in the 200-210°C range.

**Refrigeration compartments.** The refrigeration compartments, three in all, decrease in temperature as the sticks approach the exit point of the machine. There is a fair degree of latitude on the settings, but a rough guide would be  $-10^\circ\text{C}$ ,  $-12^\circ\text{C}$  and  $-17^\circ\text{C}$ .

**Machine rate.** There can be no hard and fast rule for the rate, which is dependent on the formula of the lipstick. However, an average rate would be in the region of 37 sticks/min with a high of 42 stick/min.

#### Lipstick moulding problems

Problems with lipstick moulding are illustrated in figure 5, while Table I compares lipstick faults with moulding type.

#### Laddering

This effect may be caused by any of the following: mould too cold; bulk not hot enough; filling rate too slow. The first of the mass just fills the cavity and sets, the next mass comes over the top of the initial mass and sets. This

process repeats until a series of layers are formed, thus giving a laddered appearance. The effect is particularly noticeable in pearl formulae where the platelets orientate themselves in different configurations at the various layer boundaries.

#### *Lipstick deformation*

This problem is most noticeable in softer formulae. Contraction should always take place at the top of the mould as coring, the shrinkage at the surface of the mould just sufficient to facilitate stick release. However, if the top of the mould sets prematurely, then coring cannot take place and the volume reduction must take place on the stick surface. In split moulding this normally occurs just above the tip, and in Ejectoret moulding it appears as "waisting" just above the rim of the godet.

#### *Sweating, blooming, bleeding, surface crystalline deposits*

It would take another paper to explain the causes of sweating and would involve consideration of the structure of the materials used (linear or branch-chained, functional groups, molecular length) consideration of wax solubilities in relation to the oils present and finally a physical model of lipstick structure. These are problems directly related to formulation and not to the manufacture and handling of the bulk.

#### *Effect of flaming*

When removed from its cavity the moulded stick will have a finer crystal structure on the outside than on the inside of the bullet. This structure will be finest on the Ejectoret, slightly less on the Rotomould, and far less in a central stick from the split mould. Flaming refines the surface structure still further and reduces the fine crystal structure to hyperfine. This is achieved, obviously, by melting and cooling the surface wax rapidly, which produces so small a crystal size as to be almost amorphous. Lipstick structure is not static in most cases, and rearrangements occur within the stick which can reduce this initial gloss, causing sweating, blooming, and hazing. The idea of a breathing lattice subject to changes in equilibrium must always be kept in mind when formulating any wax product.

#### *Streaking*

The reason for streaking is not fully understood. It is the pigment titanium dioxide that most usually exhibits this phenomenon. The original theory for titanium dioxide flotation was that the surface coating was partially stripped off during milling to leave a nonoil-compatible particle. However, with the incidence of iron oxide black flotation, which has no surface coating, this theory would seem unlikely. The second theory is related to particle size, postulating that some particles were so small that they could not be wetted out, but would remain as a fine flota-

tion or scum. Milling the titanium dioxide in a surface active material such as an emulsifier does not work at the present time. The third and most likely theory is related to the surface tension of the lipstick base. Reformulation or modification of the base, though a drastic step, does cure the problem, but can introduce new ones. Certain silicon oils also eliminate streaking, but produce problems on flaming. The simplest solution is to change from split moulding to one of the other methods on bulks with high titanium dioxide content, where the rapid cooling does not permit sufficient time for the pigment to float to the surface whilst in the cavity.

#### *Cratering*

This effect is mostly found in split mouldings. It shows up in flaming, when the stick develops "dimples." The main cause was found to be trace amounts of silicon oils or machinery lubrication oil from manufacturing mixers or the dispenser mixer. It is not possible to find an immediate remedy, though allowing sticks to "rest" for 2 days prior to flaming can improve the condition.

#### *Mushy failure*

The central core of the stick lacks structure. The problem is not related to a particular formula or particular shade and arises maybe once a year for a few days, then disappears. The same bulk seems to mould satisfactorily in Rotomould or Ejectoret, and granularity caused by carnauba wax seems the only explanation.<sup>15,16</sup>

#### **Lipstick structure**

##### *Ejectoret moulded stick structure*

The mould in this technique is the plastic ejectable sheath contained in the case. Since the sheath is a single component surrounded on all sides by air, one may consider the mould to be exempt from the outside influence of thermal gradients. The mass entering the sheath is immediately cooled at the surface/mass interface and forms a fine-grained lipstick skin from which the mass sets to form the bullet. The skin is composed of small wax crystals or lattice mesh which become the nuclei for a fine needle shaped crystal to grow towards the centre. This needle growth is called columnar growth.

However, the cooling rate is so rapid that the initial fine structure laid down is of such a thickness that the area of columnar growth is very small. The overall structure is therefore fairly homogeneous, with the little columnar growth present running horizontally to the centre of the stick, but most of the structure being fine-grained to such an extent as to be almost amorphous. Sticks that are frozen and sheared by a bending movement always break cleanly and at right angles to the applied force, leaving a fairly flat surface without concave dents or convex projections. None of the sticks examined showed any signs of a central core, and any patterning or markings were completely

**Table II.** Standard deviation of physical properties resulting from different moulding methods

Lipstick	Method	Test	Mean $\pm$ s.d.	% S.d. of mean	
Pearl	Rotamould <sup>⊗</sup>	Break strength	208.5 $\pm$ 26.1	12.5	
	Ejectoret <sup>⊗</sup>	Break strength	367.3 $\pm$ 66.6	18.1	
	Split	Break strength	320.3 $\pm$ 19.4	6.1	
			383.2 $\pm$ 30.5	7.9	
	Rotamould <sup>⊗</sup>	Penetration	38.2 $\pm$ 3.7	9.7	
	Ejectoret <sup>⊗</sup>	Penetration	39.3 $\pm$ 17.3	44.0	
	Split	Penetration	41.2 $\pm$ 3.8	9.3	
			46.6 $\pm$ 3.9	8.4	
	Rotamould <sup>⊗</sup>	Pay-off	0.21 $\pm$ 0.01	4.7	
	Ejectoret <sup>⊗</sup>	Pay-off	0.23 $\pm$ 0.01	4.3	
	Split	Pay-off	0.24 $\pm$ 0.01	4.1	
	Plain	Rotamould <sup>⊗</sup>	Break strength	171.6 $\pm$ 31.3	18.2
		Ejectoret <sup>⊗</sup>	Break strength	253.8 $\pm$ 14.5	5.8
		Split	Break strength	273.5 $\pm$ 34.8	12.7
				241.3 $\pm$ 27.2	11.2
Rotamould <sup>⊗</sup>		Penetration	38.1 $\pm$ 2.5	6.5	
Ejectoret <sup>⊗</sup>		Penetration	35.2 $\pm$ 11.4	32.5	
Split		Penetration	43.3 $\pm$ 4.8	10.9	
			39.0 $\pm$ 3.2	8.3	
Rotamould <sup>⊗</sup>		Pay-off	0.31 $\pm$ 0.01	3.2	
Ejectoret <sup>⊗</sup>		Pay-off	0.29 $\pm$ 0.01	3.4	
Split		Pay-off	0.31 $\pm$ 0.01	3.2	
Gloss		Rotamould <sup>⊗</sup>	Break strength	100.5 $\pm$ 17.8	17.6
		Ejectoret <sup>⊗</sup>	Break strength	214.7 $\pm$ 27.4	18.8
		Split	Break strength	194.6 $\pm$ 21.7	11.1
		Rotamould <sup>⊗</sup>	Penetration	17.7 $\pm$ 1.7	9.3
	Ejectoret <sup>⊗</sup>	Penetration	18.8 $\pm$ 1.2	6.4	
	Split	Penetration	17.6 $\pm$ 2.4	13.7	
	Rotamould <sup>⊗</sup>	Pay-off	0.39 $\pm$ 0.01	2.5	
	Ejectoret <sup>⊗</sup>	Pay-off	0.38 $\pm$ 0.01	2.6	
	Split	Pay-off	0.40 $\pm$ 0.01	2.5	

circular orientated.

#### *Split moulded sticks*

In this instance the initial picture is almost the same, with a fine grain structure lining the cavity, but considerably thinner. However, whereas the Ejectoret mass fills from the centre of the cavity, the split mould mass flows from the side, and gives rise to an interesting (if not initially puzzling) phenomenon of an oval rather than circular cross section orientation. As the mass initially runs down one side of the cavity it sets, but at the same time heats up a section of cavity in front of it. The mass rising on the opposite side of the cavity to the fill also sets, forming the second half of the skin, but the section of cavity between front and back having been pre-warmed does not set, and therefore the molten mass in the centre of the cavity is oval in shape.

Unlike the Ejectoret, the split mould cavity is surrounded by thermal gradients. The bottom of the mould stands on a cold plate, the top of the mould open to a relatively low ambient temperature, and the centre of the mould kept hot by adjacent cavities full of molten lipstick mass. Thus, whereas an Ejectoret sheath containing 5g of molten mass can set relatively unhindered in

the space of 30s, it takes 15-20 min for 500g of molten mass and 4000g of heated duralumin mould to cool and the sticks to set.

It is this time delay together with the thermal gradients which give rise to the differing structures among the sticks from each method. Instead of the columnar growth being horizontal from skin to centre, it in fact angles above and below the horizontal norm. This is because the thermal gradients produce a nonlinear temperature within the cavity, and the columnar growth must proceed from a cool site to a warmer one. Sticks broken show both concave and convex structures depending on how the sticks set and where the fracture site occurred. In pearlescent sticks particularly, the columnar growth and central oval core may be clearly seen and on some occasions the fine structure of the skin may also be seen in the sharp edge at the site of the fracture. The core itself is due to the slow cooling rate, where fractional crystallisation takes place as the mass cools. Thus, the higher melting point waxes such as carnauba tend to set before the lower melting point waxes such as beeswax. In this way the centre of the stick has a higher concentration of oils and lower melting waxes than the skin. It is also suspected that a

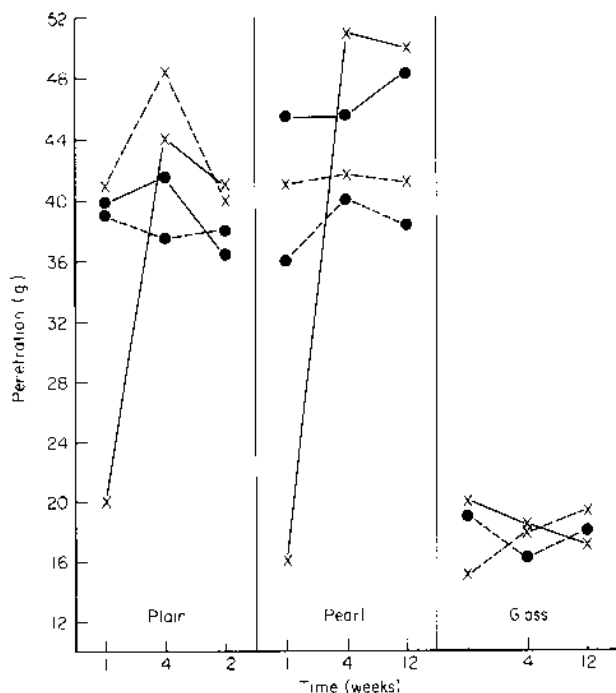

Figure 6. Penetration hardness results for different moulding methods of different lipstick formulae with time. (•---•) Rotomould (mean standard + direct); (X—X) Ejectoret (mean standard + direct); (X---X) split (mean standard); (•—•) split (mean direct).

higher concentration of impurities would be found at the centre. Broken sticks have also shown pearl migration to the centre.

#### Rotomould sticks

The structure of Rotomould sticks compares very closely to split moulded stick structure, but the central core is much smaller and more compact, with a thin pencil-lead-like core projecting from the surface of the fracture. The structure, though similar, tends to have a grainy rather than crystalline appearance, indicative of a trend to the amorphous state of Ejectoret. The fractures are less convex than those found in split moulding, which indicates an intermediate structure to split moulding and Ejectoret moulding.

#### Physical testing

- **Hardness.**<sup>4,7,18</sup> The lipstick is placed on the compression cell or an Instron tensiometer. The hardness is determined by the maximum force required to penetrate the lipstick with a needle 0.52 mm in diameter.
- **Break strength.**<sup>4,8,19-22</sup> The lipstick in its case is held at an angle of 45°C and traversed onto the Instron compression cell plate.
- **Pay-off.** A filter paper is preweighed and pinned to the platter. The lipstick is lowered onto the outer rim of the paper and loaded with a 100g weight and the handle turned. As the platter rotates under the stick, a series of gears and cams arcs the arm towards the centre. After 15 revolutions the paper is

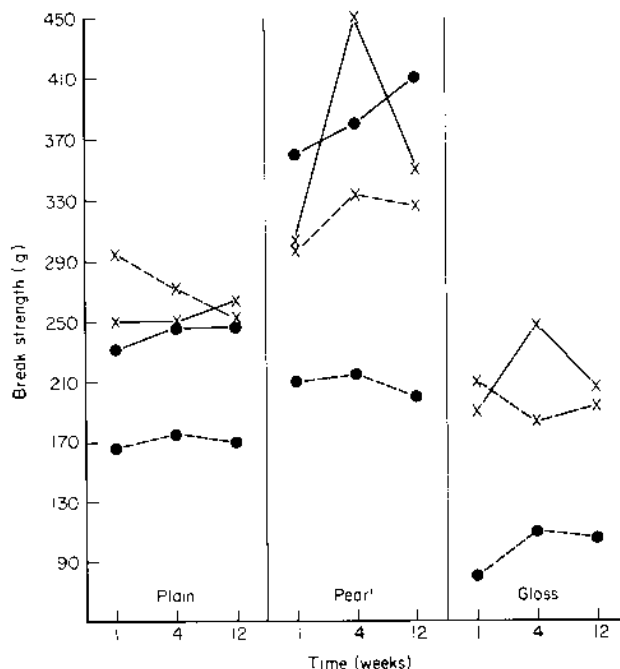

Figure 7. Break strength results for different moulding methods of different lipstick formulae with time. (•---•) Rotomould (mean standard + direct); (X—X) Ejectoret (mean standard + direct); (X---X) split (mean standard); (•—•) split (mean direct).

covered with lipstick and is removed for weighing.

#### Results—statistical significance

When all results for lipstick type, lipstick moulding method, and tests undergone are averaged out, the difference between mean results for the direct manufacturing method and the concentrate method is statistically significant for plain and pearl split moulded samples when tested for penetration hardness and break strength.

#### Moulding methods

The standard deviation (s.d.) in the results of the physical tests between different moulding methods, shown in Table II, for each lipstick type is proportionately as follows.

- **Pearl lipsticks.** Penetration hardness and break strength results show the largest s.d. for the Ejectoret method and the smallest for the split moulded method.
- **Plain lipsticks.** Penetration hardness and break strength results do not follow the same pattern.
- **Gloss lipsticks.** Again, penetration and break strength results do not follow the same pattern.
- **Pay-off results** are too small to register any significant difference in s.d.

#### Penetration hardness

Figure 6 shows that Ejectoret lipsticks (plain



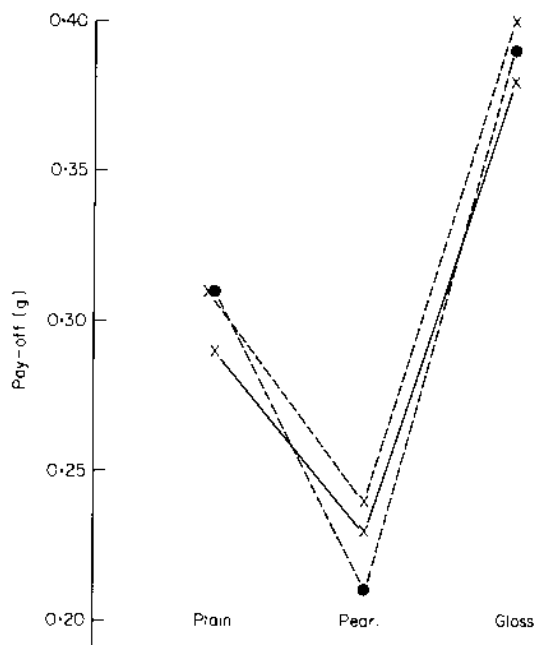

Figure 8. Variation of pay-off for different moulding methods of different lipstick formulations. (●---●) Rotomould (mean total); (X—X) Ejectoret (mean total); (X---X) split (mean total).

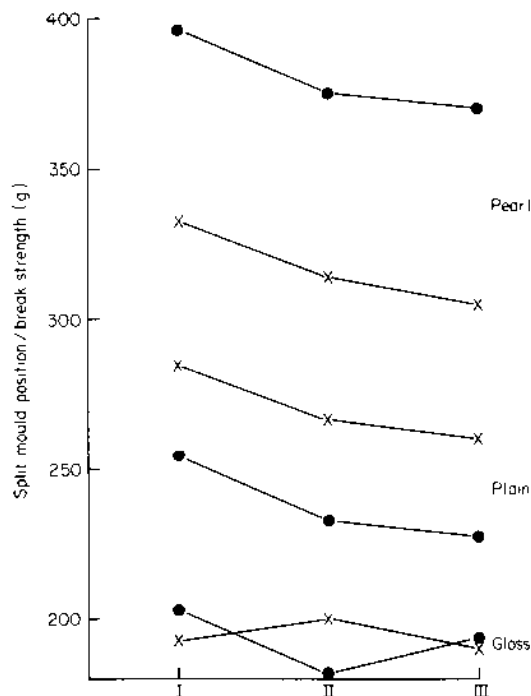

Figure 9. Variation of break strength with position in split mould for different lipstick formulae and different manufacturing methods (●—●) Direct; (X—X) standard.

and pearl) harden considerably between I and 4 weeks after moulding. Variation in split moulded and Rotamoulded lipsticks is far less with time. Rotamoulded lipsticks tend to be softer than Ejectoret or split moulded lipsticks. Very little difference in hardness is shown, either with time or moulding method, for gloss lipsticks.

#### Break strength

Generally, Ejectoret lipsticks are stronger than Rotamoulded and split moulded lipsticks. Rotamoulded lipsticks were the weakest. Changes with time are not so marked (for Ejectoret samples), as shown by the penetration and break strength results with time, lipstick type and moulding method shows a statistically very significant relationship between the two sets of results ( $r = 0.6994$ ;  $P < 0.01$ ). See figure 7.

#### Pay-off

For all moulding methods pay-off follows the trend gloss > plain > pearl (fig. 8). No significant variation of pay-off with moulding type is apparent. Comparison of penetration and pay-off results shows a statistically highly significant relationship between the two sets of results ( $r = 0.8449$ ;  $P < 0.001$ ).

#### Break strength/split mould position

Figure 9 shows that, for plain and pearl lipsticks, samples moulded in Position I are stronger than those in Position II, and Position

II lipsticks are stronger than Position III samples. The difference between I and II is larger than that between II and III. Direct method pearl samples are stronger overall than concentrate pearl samples, but the converse occurs for plain samples. No similar patterns are shown for gloss samples. A comparison of results of split mould position penetration versus split mould position break strength shows a statistically highly significant correlation ( $r = 0.8298$ ;  $P < 0.001$ ).

#### Conclusions

##### Manufacturing methods

The two manufacturing methods show a statistically significant difference only for split-moulded pearl and plain samples. Gloss samples contain such a small quantity of colour that no difference shows up. Pay-off results give very small numbers and fewer samples were tested for pay-off than for penetration and break strength.

Where the difference resulting from the two methods is significant, a similar pattern is shown between break strength and penetration, that is, in plain samples the direct method is softer and weaker than the concentrate method, whereas in pearl samples the concentrate method is softer and weaker than direct method.

The fact that the differences only show up in split moulded samples is probably due to the slower cooling rate allowing more movement of colour particles (hence no difference in low col-

our gloss samples). The inversion of plain and pearl results must therefore be caused by the presence and absence of pearl particles in addition to the colour particles.

#### *Moulding methods*

No real pattern emerges from these results to indicate whether or not one method is more variable than another. While we knew that split moulded lipsticks differed depending on their mould position, the overall variation in finished stick properties is generally less than that in Rotamould and Ejectoret moulded sticks. In these investigations only one batch of each manufactured bulk was used to test the moulding methods. However, all sticks examined were perfectly satisfactory from a user's viewpoint.

#### *Penetration hardness*

The very rapid cooling involved during Ejectoret moulding gives an unstable soft structure that equilibrates itself during the first month, to give a much harder stick. Slower cooled sticks, Rotamould and split mould, form a more stable structure that does not appear to vary significantly with time.

#### *Break strength results*

Ejectoret moulded lipsticks are stronger than other types due to the fact that they are actually moulded in the godet. Hand fitted (split moulded) samples were found to be more secure in their godets than those mechanically fitted by the Rotamould. Break strength and penetration results were shown to correlate. Logically a harder stick (unless extremely brittle) would be stronger, but firmness of fit in the godet is an additional factor. This factor shows itself for Ejectoret lipsticks which are extremely soft at one week and very much harder at 4 weeks. Break strength results show a much less marked difference between 1 and 4 weeks, indicating that the secureness of fit in the godet of Ejectoret moulded samples does play a part in the break strength of the stick.

#### *Pay-off*

As expected, pay-off results are directly related to the softness or hardness of the stick. Differences between moulding methods and manufacturing methods did not appear.

#### *Break strength/split moulded position*

The results for plain and pearl samples show that sticks moulded in Section I are stronger and harder than those in II, and sticks moulded in the middle of the mould (III) are softer still (fig. 11). This can be explained by the difference in cooling rates of the three positions: assuming that the lipstick bulk being poured is at a constant temperature, Position I samples will cool quickest due to the greatest heat differential between mould and bulk, as the mould is filled, its temperature will increase so that it will be warmer for Position III sticks, and hotter still for Position II sticks. However, Position II has ex-

ternal surfaces and will therefore cool quicker than Position III sticks. Position III sticks will therefore cool the slowest, be mushy in texture and therefore be the softest. The physical test results and the examination of structure cannot lead us to a firm conclusion about which lipstick manufacturing or moulding process is best. However, the direct method of manufacture is more costly from the capital expenditure outlay, but less time intensive and requires fewer personnel to operate. The Ejectoret has a high capital outlay but has the highest output, the lowest labour rate, and the lowest reject rate. It will handle softer bulks than Rotamould or split mould, with fewer of the quality control reject categories. Finally, the number of stages involved in moulding is reduced considerably with no need to assemble or flame the final stick.

#### **Acknowledgement**

This paper is based on a presentation at the Society of Cosmetic Scientists' Symposium on "New Manufacturing Processes" at Eastbourne, England, in November 1979, that was published in the *International Journal of Cosmetic Science*, 2(3), 143, June 1980.

#### **References**

1. M. G. deNavarre, *The Chemistry & Manufacture of Cosmetics*, Continental Press, Orlando, FL, (1975)
2. E. Sagarin, *Cosmetics, Science & Technology*, 2nd ed. Interscience, New York (1973)
3. R. G. Harry, *Principles and Practice of Modern Cosmetics (Modern Cosmetology)*, 6th Ed. p. 140. Leonard Hill, London (1973)
4. P. G. Louffer, Lipsticks. In: *Cosmetic Science and Technology* (Ed. M. S. Balsam and E. Sagarin), Vol. 1, Wiley Interscience: New York, 1972, pp. 365-392
5. F. V. Wells and I. I. Lubowe, *Cosmetics & the Skin*, Reinhold: New York, 1964, p. 188
6. A. L. Fishbach, Lipsticks, their formulation, manufacture and analysis *J. Soc. Cosmet. Chem.* **5** 242 1954
7. P. D. W. Daley, Lipsticks, modern base manufacture *J. Soc. Cosmet. Chem.* **19** 521, 1968
8. D. P. McDonald, Some new approaches to mixing and grinding operations. *Manuf. Chem.* **43** 10 1972
9. W. Dinkel, Application of corundum stone mills for lipstick production. *Cosmet. Toil.* **91** 40 1976
10. W. Kindel Grinding: key to lipstick colour dispersion. *Manuf. Chem.* **48** 28 1977
11. Schimmel Brief No. 265. Pigmented wax for colouring lipstick base, April 1965
12. N. Eisberg, Making the most of lipstick moulding. *Manuf. Chem.* **48** 25, 1977
13. A. Meier and P. D. W. Daley, Ejectoret lipstick production, Recent advances in the packaging of cosmetic and toiletry products. S.C.C. Symposium. Paper 10, November 1975
14. A. Meier and P. D. W. Daley, Ejectoret lipstick production. *Cosmet. Toil.* **91** 9, 1976
15. M. de Carames, Development of a lipstick base. *Cosmet. Toil.* **93** 15, 1978
16. G. van Ham and H. Boos, Lipstick formula variations and lipstick properties. *Cosmet. Perf.* **90** 27, 1975
17. Schimmel Brief No. 210, Quality control in lipstick manufacture, Sept. 1952
18. Davenport. Quality control in lipstick manufacture. *Proc. Toil. Goods Assn.* **4** 2, 1945
19. Norda Schimmel Brief No. 434. Strengthening lipsticks against breakage, September 1971
20. R. G. Drew, Evaluation of mechanical stresses set up in lipsticks during application. *J. Soc. Cosmet. Chem.* **29** 441, 1978
21. H. Heinrich, Stability tests on lipsticks, face powder and make-up items. *J. Soc. Cosmet. Chem.* **2** 303, 1947
22. A. Maruszewski, Steps in developing a modern lipstick. *Amer. Perf. Cosmet.* **82** 37, 1967